

RAMP STABILISATION IN PLATINUM MINE MOKOPANE (POTGIETERSRUS), LIMPOPO, ZA

GEOTECHNICAL / REINFORCED SOIL WALLS

Product: Terramesh[®] System

Problem

During mining operations, additional platinum ore was discovered within the existing access ramp system.

In order to access this ore, it was decided to excavate the ore in bulk and backfill with waste material in order to recreate the ramp. It was important to maintain the pit design limits and therefore it would be necessary to design a near-vertical wall on the original line of the access ramp.

The maximum height of the proposed structure would be 15m with a total length of 150m.

Solution

A number of options were considered, including reinforced concrete walls and a Terramesh[®] reinforced soil structure.

The structure would be exposed to extreme loads from the dump trucks using the ramp of up to 390 tonnes. Additionally, blasting stresses would be imposed upon the structure. Due to its flexibility and ability to accommodate differential settlement and loads without problems, a Terramesh[®] structure was considered the most suitable option, both technically and economically.

Due to its flexible nature, the Terramesh[®] structure was able to withstand the enormous stresses induced from blasting carried out within 8m of the structure with minimal deformation. Differential movements do not damage a Terramesh structure; the mesh simply accommodates the loads and continues working.

Designers SRK Consulting were engaged to carry out the design work on the structure on behalf of the client. They were assisted by Maccaferri Southern Africa engineers and operatives.

At the foot of the Terramesh[®] wall it is normal to use 0.5m high units where the fascia compression loads are greatest. Above a certain height on the fascia (revealed during calculations), 1m high Terramesh[®] units are used.

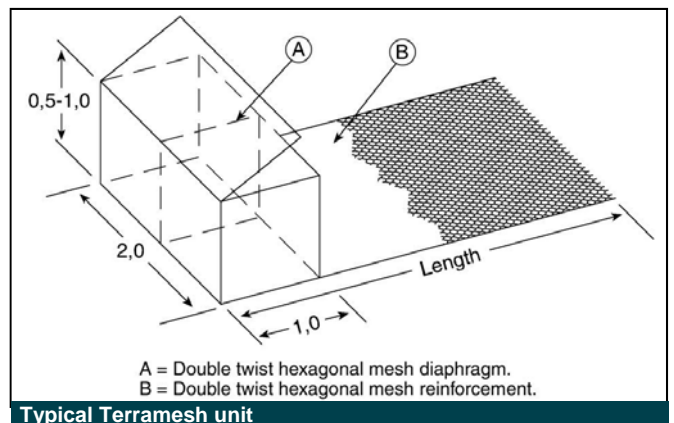

Client:

ANGLO PLATINUM

Main contractor:

ANGLO PLATINUM

Designer:

SRK CONSULTING

Products used:

TERRAMESH SYSTEM

Date of construction

SEPT-OCT 2000

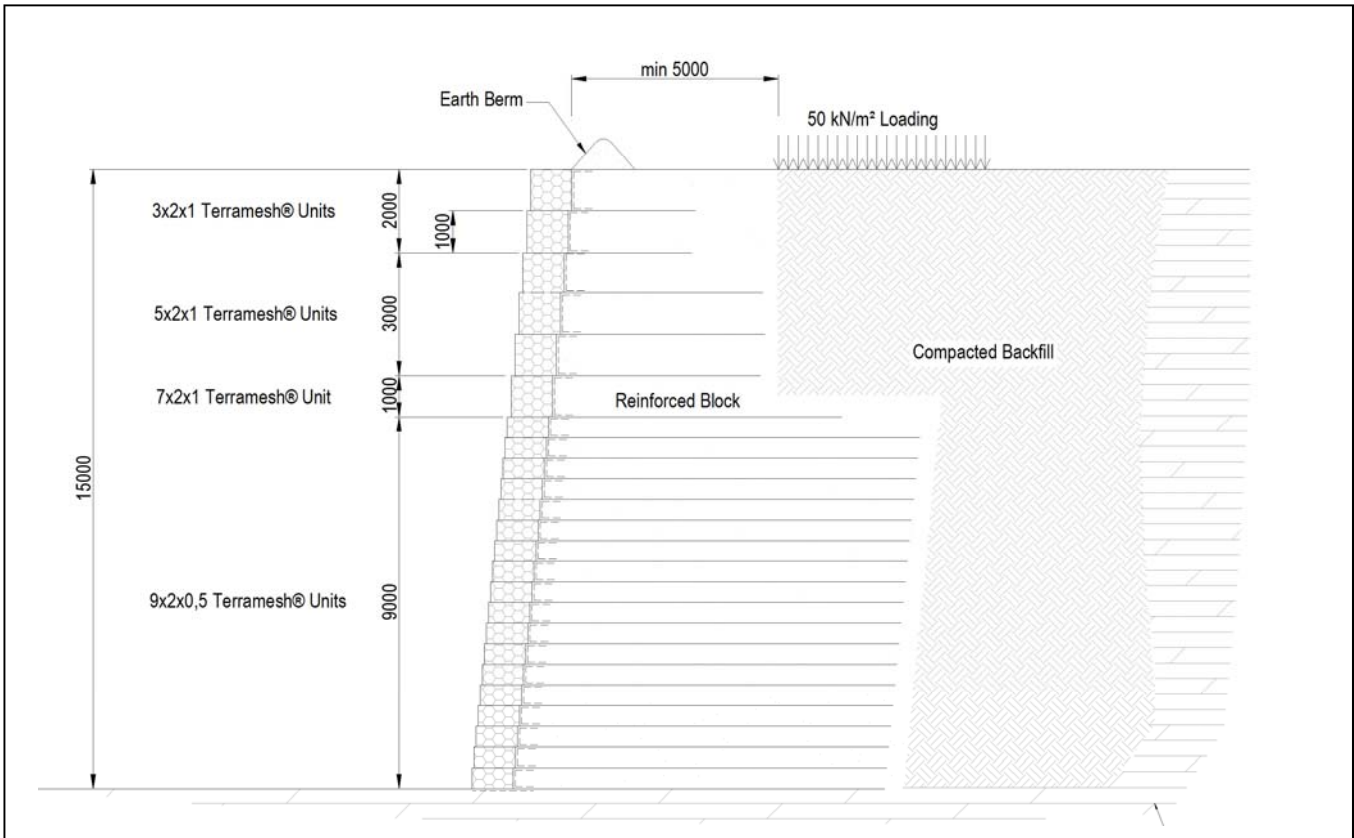

Typical cross section of Terramesh wall at 15m high section

Terramesh[®] is used to construct reinforced soil structures. A unit consists of a continuous horizontal panel of woven steel-wire mesh geogrid with an integral gabion fascia unit. This makes the system efficient and economic to construct as there is no complex connection to be made between the grid and the facing unit. Installation is quicker and there is less potential risk of errors and omissions during construction. This is particularly important in these high-load structures, where the connection between reinforcing geogrid and fascia unit is important.

The fascia unit is filled with hard durable rock-fill in the same manner as a gabion and the geogrid tail is then sandwiched between layers of compacted structural backfill. Wherever possible, Maccaferri attempts to reuse site-won material as structural backfill to these Terramesh[®] reinforced soil structures.

In this case, waste rock fill was sourced directly from the mine and local labour was employed to carry out the packing and lacing operation.

The Terramesh[™] reinforced soil structure proved to be the most cost-effective solution, with the overall project being about 40% cheaper than the alternative solutions.

Officine Maccaferri S.p.A. Global Headquarters

Via JF Kennedy 10, 40069 Zola Predosa (BO) - Italy
 T: (+39) 051 6436000 F: (+39) 051 236507
 E: comes@maccaferri.com
[www. Maccaferri.com](http://www.Maccaferri.com)

Bureau Veritas Certified Quality System Company
 with ACCREDIA and UKAS accreditation