

Interceptor[®]

Surface Drainage Specifications & Design Manual

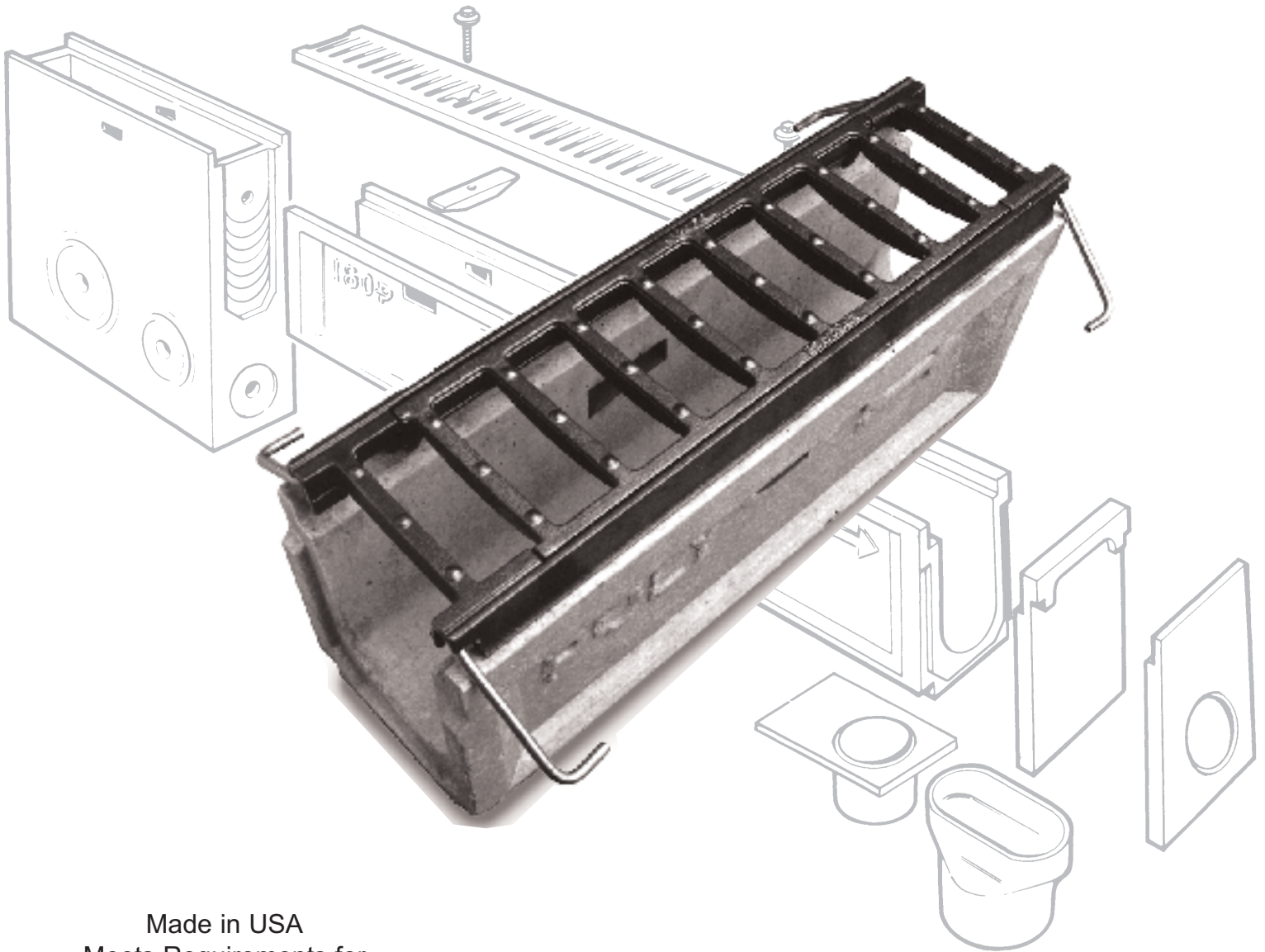

Made in USA
Meets Requirements for
Buy America

ABT[®], INC.

Advanced Building Technologies, Inc.

www.abtdrains.com

.....
Today's Hydraulic Solution



Ph 800-452-4435
Fax 615-822-9460
info@jenhill.com
www.jenhill.com

PolyDrain® Interceptor

Since 1983, PolyDrain® has been used to solve surface drainage problems throughout the construction industry. PolyDrain® polymer concrete trench drains provide the performance, longevity and durability that set the standard for surface collection systems.

With the development of the PolyDrain® Interceptor Series, some of the long standing challenges of roadway drainage can be met. The control of **excessive spread** and the elimination of **inlet bypass** can be handled efficiently and effectively, thereby limiting dangerous hydroplaning while reducing construction costs and increasing pavement service life.

Line drainage has long been recognized as an effective solution to sheet flow problems. PolyDrain® Interceptor goes beyond the limitations of the traditional slotted drain products.

PolyDrain® Channels

The 30 Standard PolyDrain® channels are one meter long and have a built-in 0.6% slope. PolyDrain® channels are manufactured from high-grade polymer resins, select quartz aggregate and inert mineral fillers creating superior strength and durability.

Polymer Concrete is resistant to salt, oil, most acids and alkalis. These features make it excellent for containing and transporting runoff in any roadway application.

By virtue of the radius bottom and low roughness coefficient, 1 meter/second (3.5 feet/second) velocities are attained when hydraulically loaded, even in flat grade conditions. Since velocities in the channels will always be higher than velocities on the pavement or gutter, the relative potential for freezing or silt build-up is greatly reduced.



Polymer Concrete is resistant to salt, oil, most acids, and alkalis. This makes it excellent for containing and transporting runoff in any roadway application.

Durability of Polymer Concrete

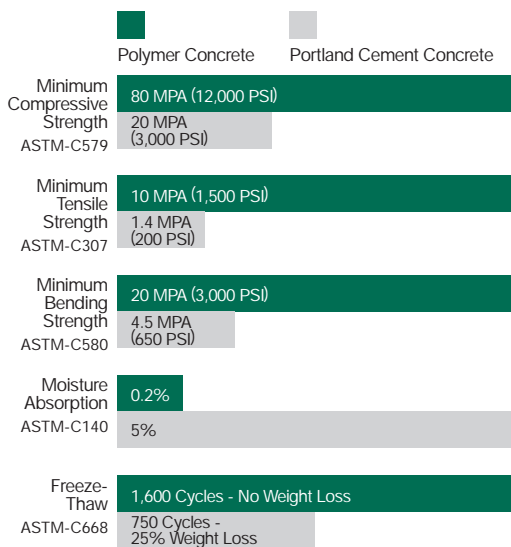

Tongue and groove joints help channels interlock and allow curved installations down to a 20 meter (65 feet) radius without modification. The low absorption rate of polymer concrete makes it an ideal material for any environmental condition.

PolyDrain® Channels offer several advantages over Portland cement concrete.

1. PolyDrain® possesses 3–5 times more compressive, tensile and bending strength.
2. Channels are nonporous and corrosion resistant with less than 0.2% absorption.
3. The smooth channel finish and geometry keeps storm water moving, providing a maintenance-friendly system.
4. When routine maintenance is required, a two-piece removable grate provides easy access.

Polymer Concrete Resistance

Fluid	Resistant
Road Salts	✓
Water	✓
Gasoline	✓
Diesel Fuel	✓
Aviation Fuel	✓
Hydraulic Oil	✓
Fuel Oil	✓
Hydraulic Fluid	✓
Motor Oil	✓
Sea Water	✓
Acids	✓

Interceptor A-67 Frame & Grate Series

Based on research conducted with Department of Transportation Hydraulics Engineers from several states, the Interceptor A-67 Frame & Grate

Series was developed to provide maximum inlet capacity while maintaining “bicycle safe” openings. Both the one-piece and two-piece designs are 1/2 meter long and incorporate four lateral anchoring lugs to help the grate withstand high-speed highway traffic and snowplow blades.

One-piece units are used under most conditions. Channels can be cleaned through the grates with high pressure wash equipment. When open access for cleaning discharge pipes or channels is required, a two-piece unit can be installed. The removable grate’s stainless steel latch mechanism is out of the flow line, preventing debris build-up.



Specifications

1. Material: 65-45-12 Ductile Iron (ASTM-A536)
2. Load Capacity: exceeds AASHTO H-25 and HS-25 load ratings
3. Inlet Area: 67% or 0.0828 m² per linear meter (0.27 ft²/LF)
4. Slot Openings: 3.98 cm (1.57 in) x 10.38 cm (4.09 in)
5. Anchoring Lugs: 6.35mm (0.25 in) x 100 mm (4 in) long



2552 : One Piece

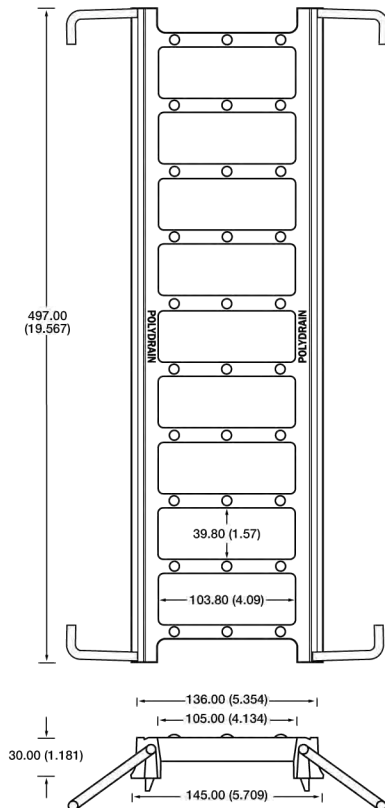

Components

- 1- #2552 One Piece Ductile Frame & Grate
- 4- #2813 Stainless Anchor Lugs

Weight

3.4 kg (7.5 lbs)

2542 : Removable

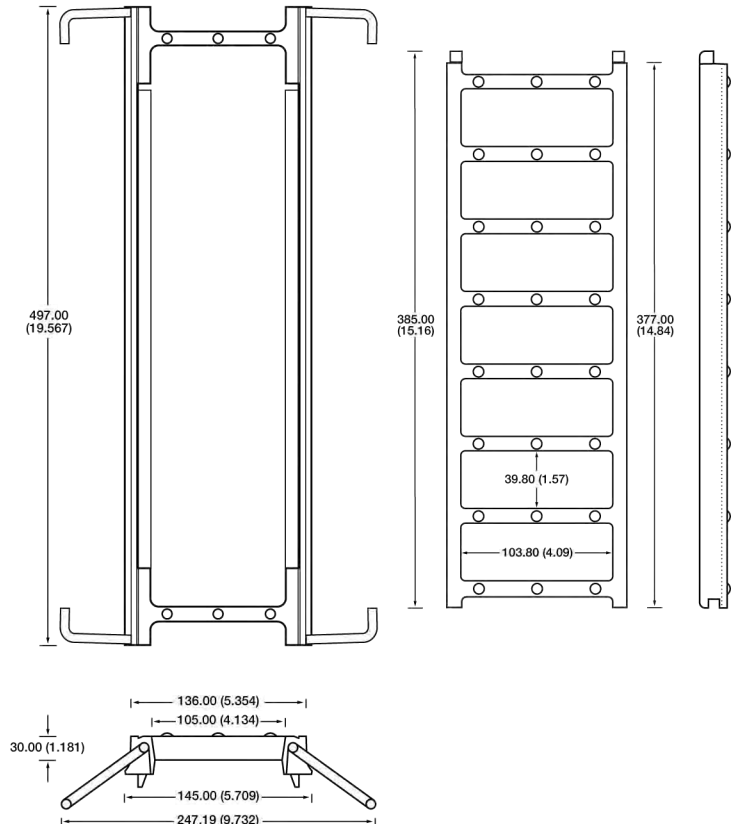

Components

- 1- #2540 Ductile Frame
- 1- #2542 Ductile Slotted Grate
- 2- #2802 Stainless Steel Latches
- 4- #2813 Stainless Anchor Lugs

Weight

4.1 kg (9.0 lbs)

Note:

For other grate configurations, refer to the PolyDrain® Sloped System Manual.

Grate Inlet Capacity

Interceptor A-67 provides the design flexibility to place the exact amount of open area just where it is required for various drainage conditions. Hydraulic testing performed by an independent laboratory has established that the inlet capacity of the A-67 grates will not be the limiting factor. The following design tools should be used to determine the length of channel and grate required under the following drainage scenarios; Curb and Gutter, Sump or Sheet Flow.

$$Q = CIA$$

Where: Q = Hydraulic Flow Quantity
 C = Surface run off coefficient (unit-less)
 I = Rainfall Intensity (inches per hour, cm per hour, etc.)
 A = Watershed Area (square feet, square meters, acres, etc.)

Curb and Gutter

This includes typical gutter flow applications adjacent to a curb or barrier. First, establish traditional inlet locations by using normal design criteria (clean out access, pipe directional change, etc.). Applying the following design information, use Interceptor A-67 to enhance the inlet capacity and control bypass flows, thereby reducing the number of expensive inlet structures that would normally be used only to restrict spread.

From allowable spread and roadway parameters, first determine maximum gutter flow using:

$$Q_G = (C_G / n) T^{2.67} S_T^{1.67} S_L^{0.5}$$

Where: Q_G = Gutter Flow (cfs)
 T = Spread (ft)
 S_T = Transverse Slope (ft/ft)
 S_L = Longitudinal Slope (ft/ft)
 n = Roughness Coefficient of Roadway
 C_G = 0.315 metric (0.468 English)

The length of Interceptor A-67 required to intercept 100% of the given gutter flow can be calculated using the following equation derived from tests conducted by FHWA and published in HEC-22, which was developed for slot type drains with widths ≥ 1.75".

$$L_D = C_c Q^{0.42} S_L^{0.3} (1.0/nS_T)^{0.6}$$

Where: C_c = 0.817 metric (0.6 English)

If less than 100% efficiency is required, solve the following equation for L₁:

$$E = Q_1/Q_G = 1.0 - (1.0 - L_1/L_D)^{1.8}$$

Where: E = Efficiency
 Q₁ = Flow to be Intercepted (cfs)
 L₁ = Length of Drain Required (ft)

Sump

This condition occurs where runoff is allowed to pond over the grate as in roadway sag curves or parking lots. Interceptor A-67 can reduce the critical nature of grading to the inlet or dependence on additional inlet structures.

Based on the depth of the water, flow condition will be either weir or orifice. For the A-67 grating, the transition between weir and orifice occurs at approximately 0.6 ft.

$$\text{Weir Flow: } Q = C_w PH^{1.5}$$

Solving for length of drain, then:

$$P = (Q/C_w H^{1.5})$$

L_D = P for flow entering one side of grate
 L_D = 1/2 P for flow entering both sides of grate.

Where: L_D = Length of Drain (ft)
 Q = Flow (cfs)
 P = Perimeter of Grate (ft)
 H = Hydraulic Head Above Grate (ft)
 C_w = 1.4 metric (2.48 English)

$$\text{Orifice Flow: } Q = 0.8 A(2gH)^{0.5}$$

Solving for length of drain, then:

$$L_D = (Q/K_o) H^{0.5}$$

Where: L_D = Length of Drain (ft)
 Q = Flow (cfs)
 A = 0.0828m²/m • L_D (0.27 ft²/ft • L_D)
 g = Gravitation Acceleration
 9.81 m/s² (32.2 ft/s²)
 H = Hydraulic Head Above Grate (ft)
 K_o = 0.29 metric (1.73 English)

Sheet Flow

This runoff occurs perpendicular to the trench and flows with a relatively uniform depth along the entire trench. Interceptor A-67 can help control sheet flows that cause dangerous hydroplaning at commercial or residential entrances or multi-lane super-elevations. Hydraulic testing, performed by an independent laboratory, establishes the intercept capability of the Interceptor A-67 grate at 0.011 m³/s/m (.12 cfs/ft), so

$$L_D = Q/C_s$$

Where: L_D = Length of Drain (ft)
 Q = Flow (cfs)
 C_s = 0.011 metric (0.12 English)

Hydraulic Capacity of Grated Line Drain

Site Slope (S_c)	Hydraulic Capacity, Q (cfs)		
	Channel Invert at 12.4" (300 Channel)	Channel Invert at 19.5" (300 w/PWI)	Channel Invert at 26.6" (300 w/PWII)
0.00	0.95	1.62	2.29
0.0025	1.13	1.93	2.72
0.0050	1.29	2.19	3.09
0.0075	1.43	2.43	3.43
0.0100	1.56	2.64	3.73
0.0125	1.67	2.84	4.01
0.0150	1.78	3.03	4.27
0.0175	1.89	3.20	4.52
0.0200	1.98	3.37	4.76
0.0225	2.08	3.53	4.98
0.0250	2.17	3.68	5.19
0.0275	2.25	3.82	5.40
0.0300	2.33	3.96	5.60
0.0325	2.41	4.10	5.79
0.0350	2.49	4.23	5.97
0.0375	2.57	4.36	6.15
0.0400	2.64	4.48	6.33
0.0425	2.71	4.60	6.50
0.0450	2.78	4.72	6.65
0.0475	2.84	4.83	6.82
0.0500	2.91	4.94	6.98



The following nomograph is provided as a quick reference for the majority of applications where $S_T = 0.02$ and $n = .015$. Locate intersection of spread and S_T lines, then drop straight down to find drain length required.

Drain Length at $S_T = 0.02$ and $n = 0.015$

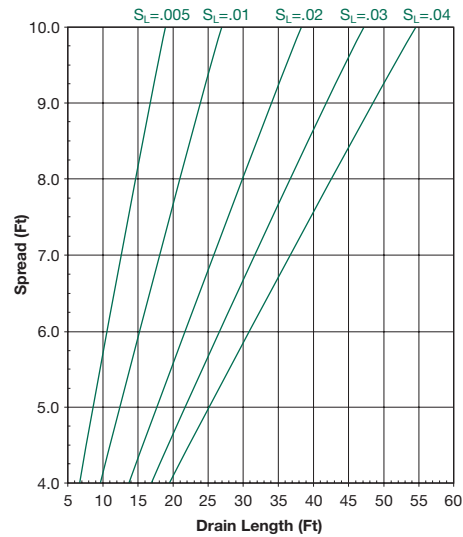

Run Variations

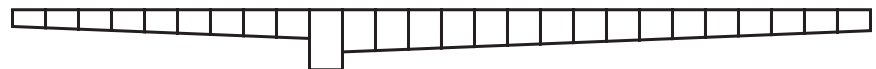

Slope to center

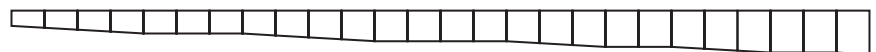

Step down with neutrals



Runs can be designed to provide an outlet at any point.



Neutral bottom non-sloping

System Schematic

The PolyDrain® Trench System consists of 30 interlocking channels, each one meter (39.19") long. Non-sloping channels can be inserted at specified intervals in order to extend channel runs. Catch basins, horizontal outlet plates, closed end plates and vertical outlet plate adapters can be installed at designated locations. Closed end plates terminate channel runs.

NOTE: Always begin at the appropriate outlet channel, working towards the shallow end.

Channel Design

PolyDrain® channels closely match the hydraulic requirements of urban roadway drainage. In roadway design, the channels can evacuate up to 8' of gutter width (or spread) intercepted by the grates. To determine the largest channel size required to convey the anticipated flows, K-values have been developed for each channel. These are a simplification of Manning's Equation.

TABLE A lists these values in terms of m³/s and cfs.

$$K_{\text{Required}} = \frac{Q}{(S_{\text{Total}})^{0.5}}$$

Where: Q = Flow intercepted by the grates

$$S_{\text{Total}} = S_s + S_c$$

S_s = Site Slope

S_c = Built-In Channel Slope

Note:

2552 A - One-Piece This system is installed in encasement concrete creating a non-removable unit.

2542 A - Removable This system comes pre-assembled (replacement parts are available separately). The frame and anchors are encased into concrete with trench access being achieved by disengaging the latches to remove the grate.

To disengage removable grate, locate latches by reaching through the last grate slot at frame end with embossed 'PolyDrain®.' Rotate latches 90° upward toward top of grate, then slide back. Lift grate upward from this end while disengaging from frame at opposite end. To reinstall and lock grate, reverse procedure.

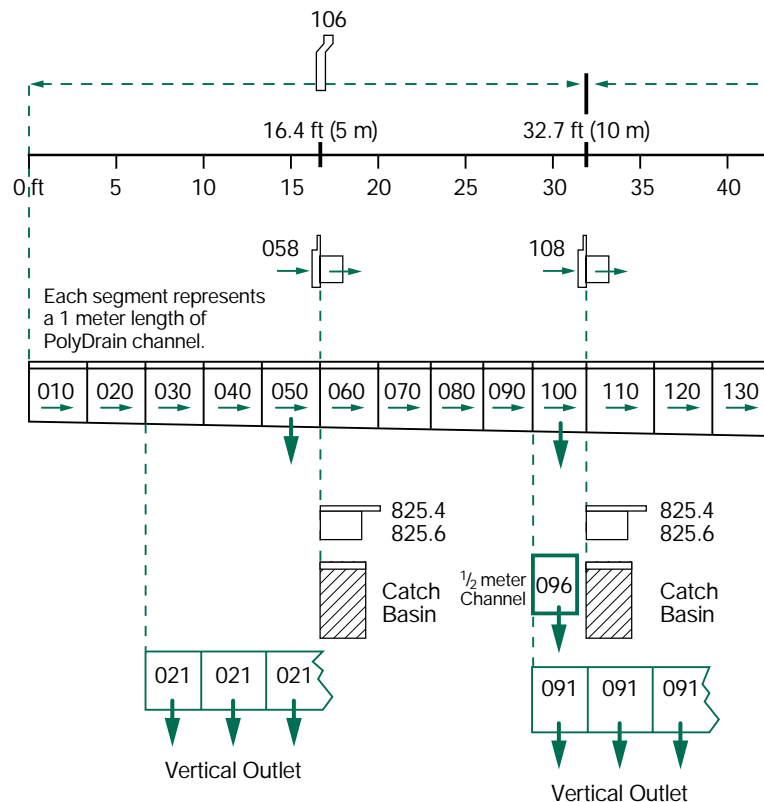

Part No.	Channel with Interceptor Frame and Grate			
	Overall Channel Depth cm (in)		Hyd. Flow Constant (K) cms (cfs)	Weight kg (lbs)
	Minimum	Maximum		
010	15.9 (6.3)	16.5 (6.5)	0.124 (4.39)	14.1 (31)
020	16.5 (6.5)	17.1 (6.7)	0.132 (4.66)	14.9 (33)
021	17.1 (6.7)	17.1 (6.7)	—	14.5 (32)
030	17.1 (6.7)	17.7 (7.0)	0.140 (4.93)	15.3 (34)
040	17.7 (7.0)	18.3 (7.2)	0.1472 (5.20)	15.6 (34)
050	18.3 (7.2)	18.9 (7.4)	0.1549 (5.47)	15.4 (34)
060	18.9 (7.4)	19.5 (7.7)	0.1626 (5.74)	16.0 (35)
070	19.5 (7.7)	20.1 (7.9)	0.170 (6.01)	16.5 (36)
080	20.1 (7.9)	20.7 (8.1)	0.1779 (6.28)	16.8 (37)
090	20.7 (8.1)	21.3 (8.4)	0.1856 (6.55)	17.3 (38)
091	21.3 (8.4)	21.3 (8.4)	—	17.0 (37)
096	21.3 (8.4)	21.3 (8.4)	—	9.7 (21)
100	21.3 (8.4)	21.9 (8.6)	0.1933 (6.83)	17.1 (38)
110	21.9 (8.6)	22.5 (8.9)	0.2011 (7.10)	18.1 (40)
120	22.5 (8.9)	23.1 (9.1)	0.2088 (7.37)	18.5 (41)
130	23.1 (9.1)	23.7 (9.3)	0.2165 (7.65)	19.3 (42)
140	23.7 (9.3)	24.3 (9.6)	0.2243 (7.92)	19.5 (43)
150	24.3 (9.6)	24.9 (9.8)	0.232 (8.19)	19.4 (43)
160	24.9 (9.8)	25.5 (10.0)	0.240 (8.47)	20.1 (44)
170	25.5 (10.0)	26.1 (10.3)	0.2475 (8.74)	20.5 (45)
180	26.1 (10.3)	26.7 (10.5)	0.2553 (9.02)	21.0 (46)
190	26.7 (10.5)	27.3 (10.7)	0.2631 (9.29)	21.3 (47)
191	27.3 (10.7)	27.3 (10.7)	—	21.2 (47)
200	27.3 (10.7)	27.9 (11.0)	0.2709 (9.56)	21.3 (47)
210	27.9 (11.0)	28.5 (11.2)	0.2786 (9.84)	22.1 (49)
220	28.5 (11.2)	29.1 (11.5)	0.2864 (10.1)	22.6 (50)
230	29.1 (11.5)	29.7 (11.7)	0.2942 (10.4)	22.7 (50)
240	29.7 (11.7)	30.3 (11.9)	0.302 (10.7)	23.4 (52)
250	30.3 (11.9)	30.9 (12.2)	0.310 (10.9)	23.0 (51)
260	30.9 (12.2)	31.5 (12.4)	0.3176 (11.2)	23.8 (52)
270	31.5 (12.4)	32.1 (12.6)	0.3254 (11.5)	24.1 (53)
280	32.1 (12.6)	32.7 (12.9)	0.3332 (11.8)	24.8 (55)
290	32.7 (12.9)	33.3 (13.1)	0.341 (12.0)	25.0 (55)
291	33.3 (13.1)	33.3 (13.1)	—	24.3 (53)
300	33.3 (13.1)	33.9 (13.3)	0.349 (12.3)	25.3 (56)

Part No.	Channel With PolyWall I and Interceptor Frame and Grate			
	Overall Channel Depth cm (in)		Hyd. Flow Constant (K) cms (cfs)	Weight kg (lbs)
	Minimum	Maximum		
010	33.9 (13.3)	34.5 (13.6)	0.364 (12.9)	37.7 (83)
020	34.5 (13.6)	35.1 (13.8)	0.3719 (13.1)	38.5 (85)
021	35.1 (13.6)	35.1 (13.8)	—	38.1 (84)
030	35.1 (13.8)	35.7 (14.1)	0.380 (13.4)	38.8 (85)
040	35.7 (14.1)	36.3 (14.3)	0.3876 (13.7)	39.1 (86)
050	36.3 (14.3)	36.9 (14.5)	0.3954 (14.0)	38.9 (86)
060	36.9 (14.5)	37.5 (14.8)	0.4032 (14.2)	39.5 (87)
070	37.5 (14.8)	38.1 (15.0)	0.4111 (14.5)	40.0 (88)
080	38.1 (15.0)	38.7 (15.2)	0.4189 (14.8)	40.4 (89)
090	38.7 (15.2)	39.3 (15.5)	0.4267 (15.1)	40.8 (90)
091	39.3 (15.5)	39.3 (15.5)	—	40.5 (89)
096	39.3 (15.5)	39.3 (15.5)	—	33.3 (73)
100	39.3 (15.5)	39.9 (15.7)	0.4346 (15.3)	40.6 (89)
110	39.9 (15.7)	40.5 (15.9)	0.4424 (15.6)	41.6 (92)
120	40.5 (15.9)	41.1 (16.2)	0.4502 (15.9)	42.0 (92)
130	41.1 (16.2)	41.7 (16.4)	0.4581 (16.2)	42.8 (94)
140	41.7 (16.4)	42.3 (16.7)	0.4659 (16.5)	43.0 (95)
150	42.3 (16.7)	42.9 (16.9)	0.4738 (16.7)	42.9 (94)
160	42.9 (16.9)	43.5 (17.1)	0.4816 (17.0)	43.6 (96)
170	43.5 (17.1)	44.1 (17.4)	0.4895 (17.3)	44.0 (97)
180	44.1 (17.4)	44.7 (17.6)	0.4973 (17.6)	44.5 (98)
190	44.7 (17.6)	45.3 (17.8)	0.5051 (17.8)	44.8 (99)
191	45.3 (17.8)	45.3 (17.8)	—	44.7 (98)
200	45.3 (17.8)	45.9 (18.1)	0.513 (18.1)	44.9 (99)
210	45.9 (18.1)	46.5 (18.3)	0.5208 (18.4)	45.6 (100)
220	46.5 (18.3)	47.1 (18.5)	0.5287 (18.7)	46.2 (102)
230	47.1 (18.5)	47.7 (18.8)	0.5365 (18.9)	46.3 (102)
240	47.7 (18.8)	48.3 (19.0)	0.5444 (19.2)	47.0 (103)
250	48.3 (19.0)	48.9 (19.3)	0.5522 (19.5)	46.5 (102)
260	48.9 (19.3)	49.5 (19.5)	0.560 (19.8)	47.4 (104)
270	49.5 (19.5)	50.1 (19.7)	0.5679 (20.1)	47.6 (105)
280	50.1 (19.7)	50.7 (20.0)	0.5758 (20.3)	48.3 (106)
290	50.7 (20.0)	51.3 (20.2)	0.5836 (20.6)	48.5 (107)
291	51.3 (20.2)	51.3 (20.2)	—	47.8 (105)
300	51.3 (20.2)	51.9 (20.4)	0.591 (20.9)	48.8 (107)

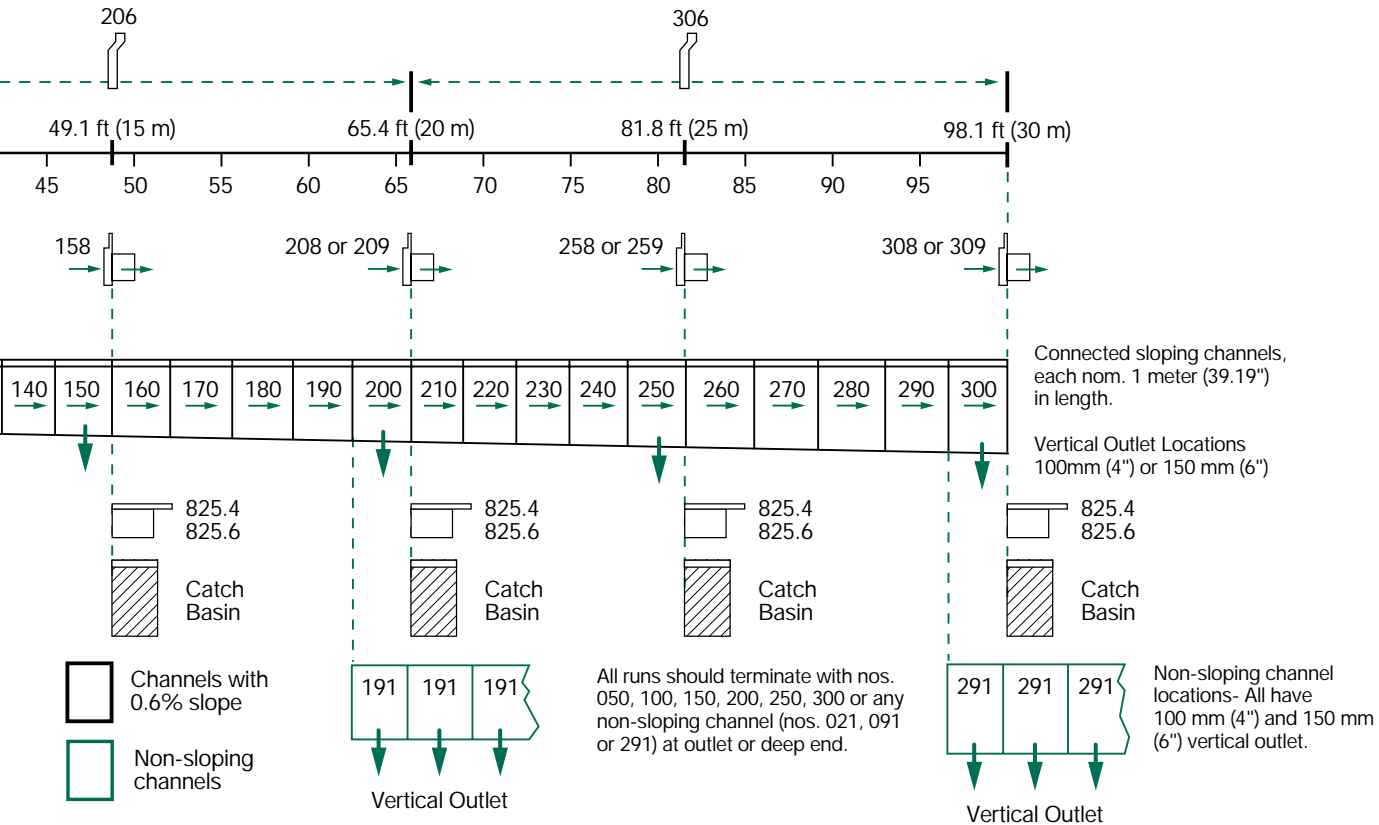

Channel With PolyWall II and Interceptor Frame and Grate				
Overall Channel Depth cm (in)		Hyd. Flow Constant (K) cms (cfs)	Weight kg (lbs)	Part No.
Minimum	Maximum			
51.9 (20.4)	52.5 (20.7)	0.607 (21.4)	52.3 (115)	010
52.5 (20.7)	53.1 (20.9)	0.615 (21.7)	53.0 (117)	020
53.1 (20.9)	53.1 (20.9)	—	52.7 (116)	021
53.1 (20.9)	53.7 (21.1)	0.623 (22.0)	53.4 (118)	030
53.7 (21.1)	54.3 (21.4)	0.631 (22.3)	53.7 (118)	040
54.3 (21.4)	54.9 (21.6)	0.638 (22.5)	53.5 (118)	050
54.9 (21.6)	55.5 (21.9)	0.646 (22.8)	54.1 (119)	060
55.5 (21.9)	56.1 (22.1)	0.654 (23.1)	54.6 (120)	070
56.1 (22.1)	56.7 (22.3)	0.662 (23.4)	55.0 (121)	080
56.7 (22.3)	57.3 (22.6)	0.670 (23.7)	55.4 (122)	090
57.3 (22.6)	57.3 (22.6)	—	55.1 (121)	091
57.3 (22.6)	57.3 (22.6)	—	47.9 (105)	096
57.3 (22.6)	57.9 (22.8)	0.678 (23.9)	55.2 (122)	100
57.9 (22.8)	58.5 (23.0)	0.686 (24.2)	56.2 (124)	110
58.5 (23.0)	59.1 (23.3)	0.693 (24.5)	56.6 (125)	120
59.1 (23.3)	59.7 (23.5)	0.701 (24.8)	57.4 (126)	130
59.7 (23.5)	60.3 (23.7)	0.709 (25.0)	57.6 (127)	140
60.3 (23.7)	60.9 (24.0)	0.717 (25.3)	57.5 (127)	150
60.9 (24.0)	61.5 (24.2)	0.725 (25.6)	58.2 (128)	160
61.5 (24.2)	62.1 (24.4)	0.733 (25.9)	58.6 (129)	170
62.1 (24.4)	62.7 (24.7)	0.741 (26.2)	59.1 (130)	180
62.7 (24.7)	63.3 (24.9)	0.749 (26.4)	59.4 (131)	190
63.3 (24.9)	63.3 (24.9)	—	59.3 (131)	191
63.3 (24.9)	63.9 (25.2)	0.756 (26.7)	59.5 (131)	200
63.9 (25.2)	64.5 (25.4)	0.764 (27.0)	60.2 (133)	210
64.5 (25.4)	65.1 (25.6)	0.772 (27.3)	60.8 (134)	220
65.1 (25.6)	65.7 (25.9)	0.780 (27.5)	60.9 (134)	230
65.7 (25.9)	66.3 (26.1)	0.788 (27.8)	61.5 (135)	240
66.3 (26.1)	66.9 (26.3)	0.796 (28.1)	61.1 (134)	250
66.9 (26.3)	67.5 (26.6)	0.804 (28.4)	62.0 (136)	260
67.5 (26.6)	68.1 (26.8)	0.811 (28.7)	62.2 (137)	270
68.1 (26.8)	68.7 (27.0)	0.819 (28.9)	62.9 (138)	280
68.7 (27.0)	69.3 (27.3)	0.827 (29.2)	63.1 (139)	290
69.3 (27.3)	69.3 (27.3)	—	62.4 (137)	291
69.3 (27.3)	69.9 (27.5)	0.835 (29.5)	63.4 (140)	300

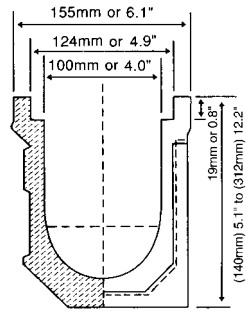

- Minimum overall depth (No. 010) 128 mm or 5.1"
- Maximum overall depth (No. 300) 309 mm or 12.2"
- Inside top width (all channels) 100 mm or 4.0"
- Maximum cross section flow area 25,400 mm² or 39.9 sq. in.
- Length of slope system 30 m or 98.1 feet
- Channel bottom thickness 20 mm or 1.0" (nom.)

PolyDrain® systems can be extended to greater lengths by insertion of any number of non-sloping channels (No. 021, 091, 096, 191, and 291) at the appropriate locations, or by the addition of PolyWall sidewall extensions.

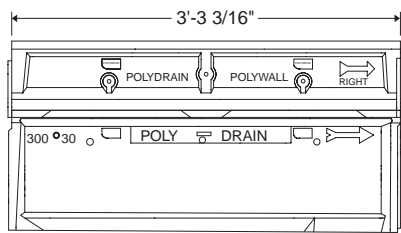
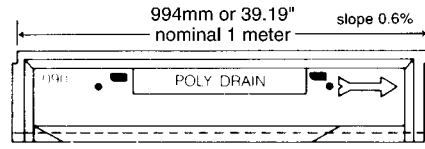

Channel with PolyWall I

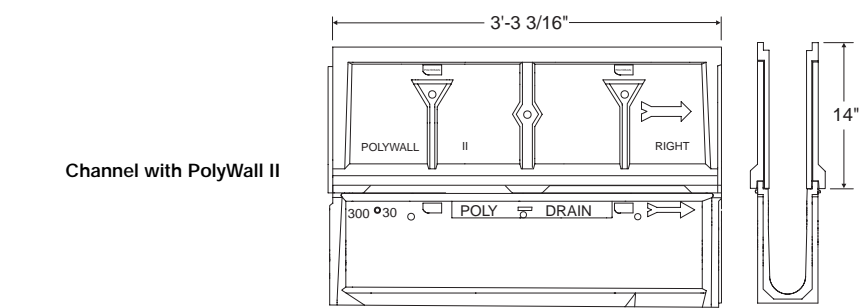

Channel with PolyWall II

Catch Basin Hydraulic & Channel Outlet Design

Once total trench flow is determined and all site conditions have been considered, match the outlet type and size to these factors. For discharge directly from the channel, refer to **TABLE B** for vertical and horizontal outlet plate capacities. For catch basin discharge rates, refer to **TABLE C**. When the Interceptor is used in conjunction with traditional inlets or manholes, a vertical miter outlet can be used without restricting the flow.

TABLE B: Channel - Pipe Discharge Capacity

VERTICAL		
Channel Number	Flow in m³/s (cfs)	
	100mm (4") dia.	150mm (6") oval
021	0.010 (0.342)	0.019 (0.652)
050	0.011 (0.371)	0.020 (0.707)
091	0.012 (0.407)	0.022 (0.774)
100	0.012 (0.415)	0.022 (0.790)
150	0.013 (0.455)	0.025 (0.866)
191	0.014 (0.484)	0.026 (0.922)
200	0.014 (0.491)	0.027 (0.935)
250	0.015 (0.525)	0.028 (1.000)
291	0.016 (0.551)	0.030 (1.048)
300	0.016 (0.557)	0.030 (1.060)
HORIZONTAL		
050	0.008(0.277)	N/A
100	0.009(0.332)	N/A
150	0.011(0.379)	N/A
200	0.012(0.421)	0.020 (0.707)
250	0.013(0.459)	0.022 (0.791)
300	0.014(0.494)	0.025 (0.866)

TABLE C - Catch Basin Discharge Capacity

Catch Basin Model	Flow in m³/s (cfs)				
	Head=Bottom of Grate				
	100mm (4")	150mm (6")	200mm (8")	250mm (10")	300mm (12")
610	0.267 (0.94)	0.060 (2.12)	0.107 (3.76)	0.167 (5.88)	0.240 (8.47)
611	0.034 (1.18)	0.075 (2.66)	0.134 (4.74)	0.210 (7.40)	0.302 (10.7)
900	0.022 (0.79)	0.050 (1.77)	0.089 (3.15)	0.139 (4.92)	0.201 (7.08)

Note: For discharge capacity requiring 15" and larger piping, contact ABT.

PolyWall Sidewall Extensions

PolyWall I and II Sidewall Extensions allow the designer or contractor to extend a continuous-sloping channel run from 30 m (98.1') to 90 m (294.3') without necessity of a catch basin or outlet.



Vertical Miter Outlet

Vertical Miter Outlet

This prefabricated special channel allows unrestricted flow from trench to inlet structure. The 30° vertical miter outlet brings the channel into the side of the structure well below the grate frame. The assembly includes steel filler and solid cast iron covers.

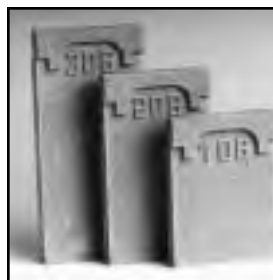

Solid End Plates



150 mm (6") Horizontal Outlet Plates

Closed and Outlet Plates

Closed end plates cap off trench runs, typically at the shallow (upstream) end. Horizontal and vertical outlet plates allow pipe connections in either direction. 150 mm (6") connectors are SDR35, 100 mm (4") are SDR35.

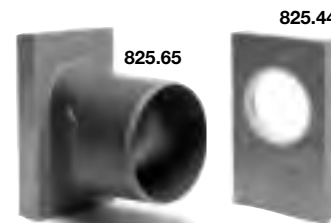

Vertical Outlet Plates

Suspended Installation

Secure 2" x 4" boards across channel using bolts or threaded rod and PolyDrain® lock toggles, one assembly at each red dot. Mask the grate openings to prevent concrete from entering the channels during placement.

Insert anchor lugs into all four corners of each frame. With channels properly positioned, secure 2" x 4" to supporting surface to prevent lift during concrete placement. Place and consolidate concrete under and around channels, then finish to proper grade. 2" x 4"s can be removed once concrete has become stiff enough to finish.

This method is also suitable for retrofit installations where an existing surface can serve to suspend the channel sections or in new construction where forming lumber is in place.

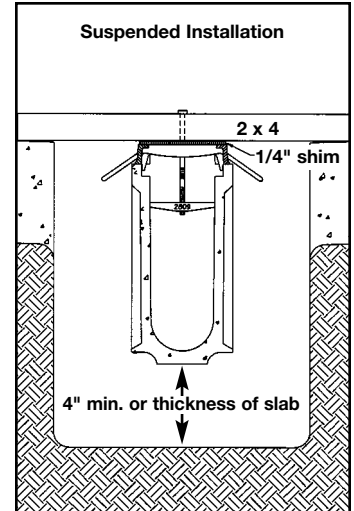

PolyClip Installation

PolyClips are installed at the channel joints. Height adjustment is made by loosening the wingnut and sliding brackets up or down the U-legs. Tightening the wingnut fixes the height while, at the same time, drawing the channels together for a tight joint. Channels can then be secured to the subgrade either by pouring a non-structural anchor slab or by driving two rebar stakes (#3 or #4) through preformed holes in the U-leg.

PolyClip Installation Aids

PolyClip was developed to speed channel installation and make the joining of the channels more secure before the pour. PolyClip consists of: two special securing brackets (one for either side of the channel); a "no-float" U-shaped leg that serves to maintain proper height and keep channels from floating during the pour; and a securing bolt to keep the PolyClip attached to the channel.



Note – Rebar not included.

Installation Kit

Used for suspending channels and grates, the kit consists of a toggle bar and bolt which engages the channel red dots.



Installation Kit

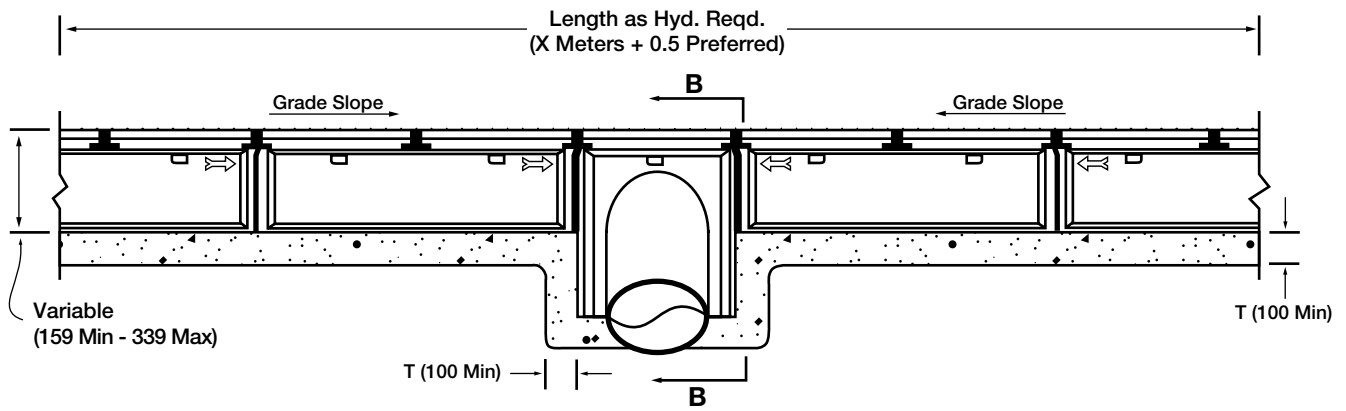

▲ SAG or Center Outlet ▼

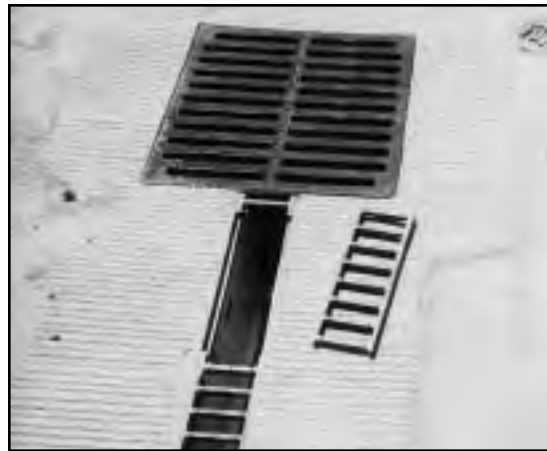

▲ Inlet Bypass Control ▼

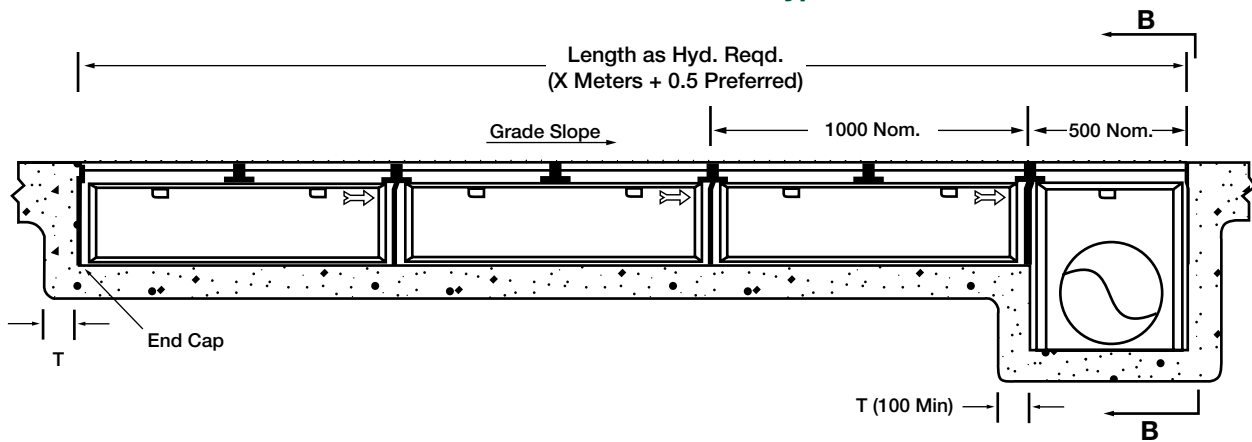

EPS Outlet Connection

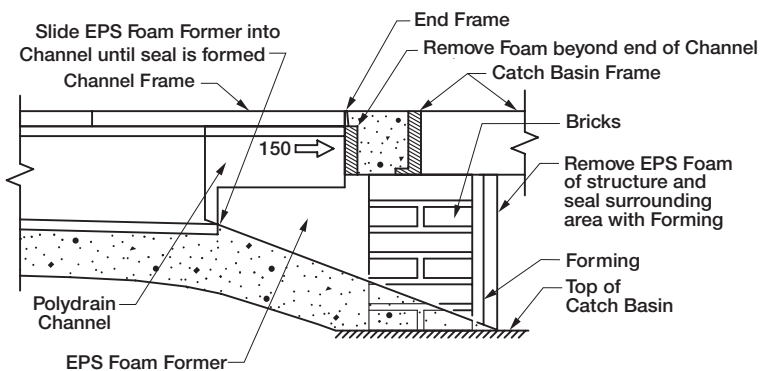

45°-Miter Outlet Connection

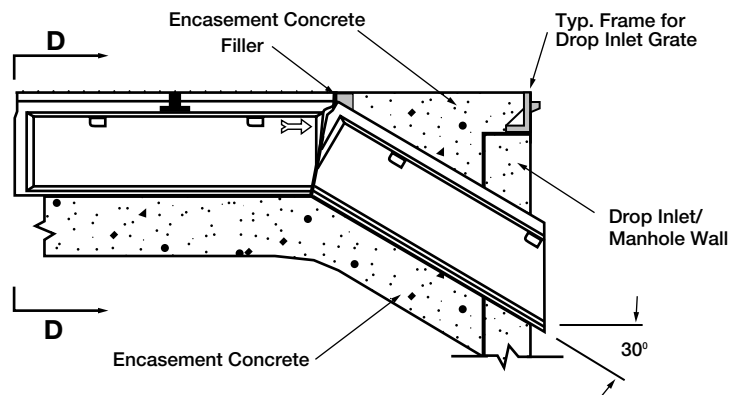



◀ Vertical Outlet Connection ▼

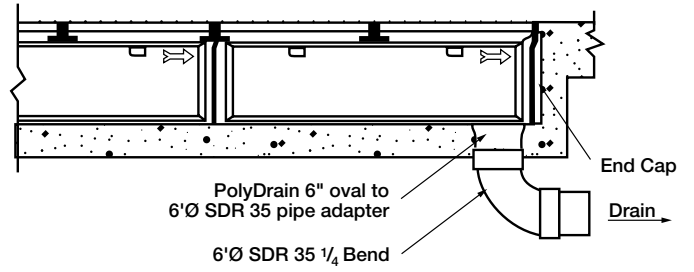

▼ Horizontal Outlet Connection ▶

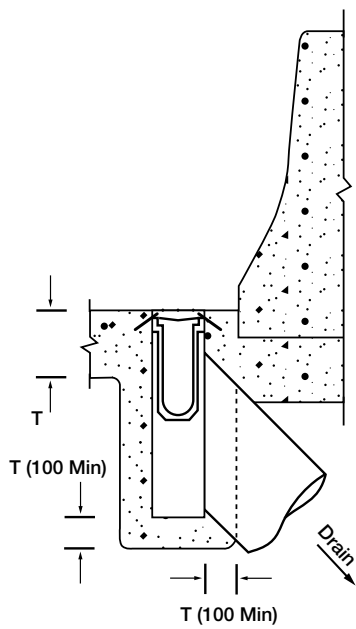
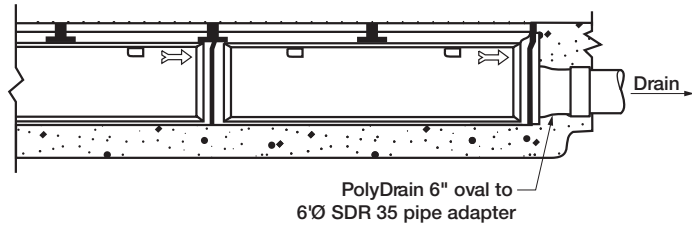

◀ Jersey Barrier and Retaining Wall

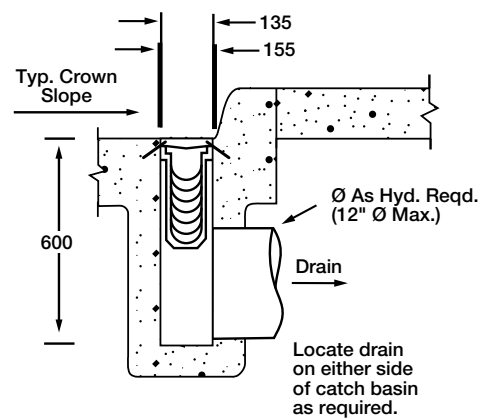

Catch Basins

Where no existing inlet structure is present, either of two polymer concrete catch basins can be installed. The smaller #900 catch basin is suitable for applications with depth restrictions, having a maximum invert of 570 mm (22.5"). This narrow profile structure fits within a standard 18" gutter width. The larger #611 is 325 mm (12.8") x 498 mm (19.6") and comes with its own frame and grate. The #611 offers a maximum invert of 1240 mm (50.0"). Refer to **TABLE C** for maximum pipe diameter.



600 Series Grates

Slotted Grates For 600 Series Catch Basins

Part No.	Load Class	Material	Length m (in)	Weight kg (lb)	Locking Device
♿ H20 604	A-B-C-D	Gray iron (class 30)	0.48 (18.87)	24.9 (55)	828
♿ H20 614	A-B-C-D-E	Ductile iron	0.48 (18.87)	39.5 (87)	828

900 Series Small Catch Basins

PolyDrain®'s 900 Series Catch Basins have the same outside dimensions as standard PolyDrain® channels. Designed to accept sidewall extensions, they can be positioned any place in a channel run.



900 Series

610 Large Catch Basin

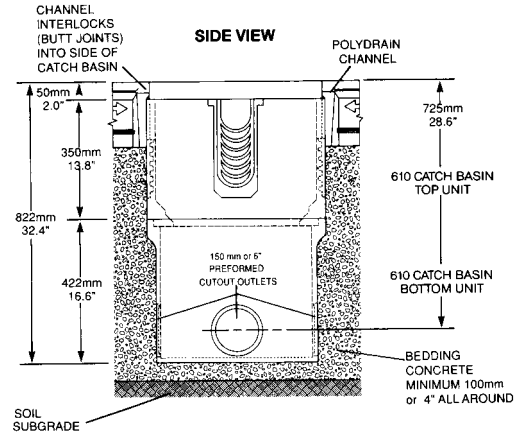

611 Large Catch Basin

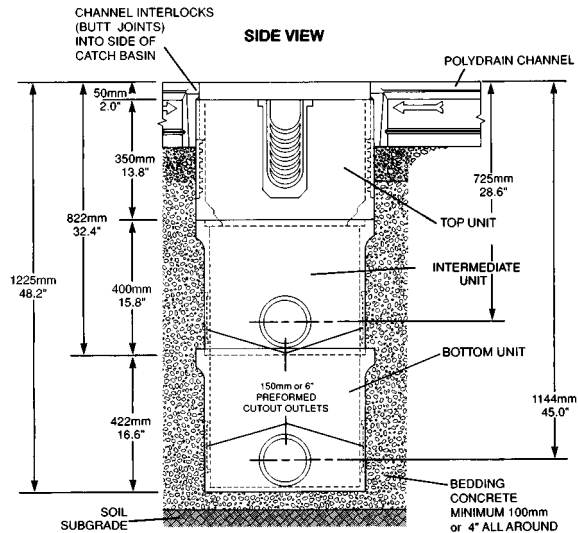

900 Series Small Catch Basins

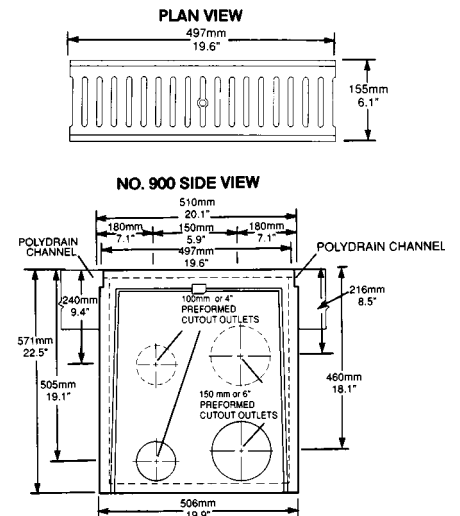

Maintenance with A-67 Interceptor System



Easy access with two-piece removable grate



Easy retrofit for existing water ponding problems



Bicycle safe



Less downtime for repairing drainage problems



Easy site assembly

Benefits for Maintenance Personnel

- Increased velocity of surface fluid helps move small debris through system
- Easily cleaned with vacuum or high pressure hose
- Recessed installation means no exposure to snowplow blades or other equipment
- A-67 can be installed without disturbing underground utilities
- Product is readily available and made in USA

Interceptor System vs. Conventional Methods

Interceptor vs. Slotted Drain

ABT, Inc. Interceptor System provides a larger inlet area, enhancing the interception capability along with providing easy access for maintenance. The smooth flow surface (Manning's $n=0.010$) and additional sidewall extensions provide high hydraulic capacities while maintaining a narrow cross section. Highly corrosive environments have little impact on the Interceptor System, providing extended design life over conventional materials.

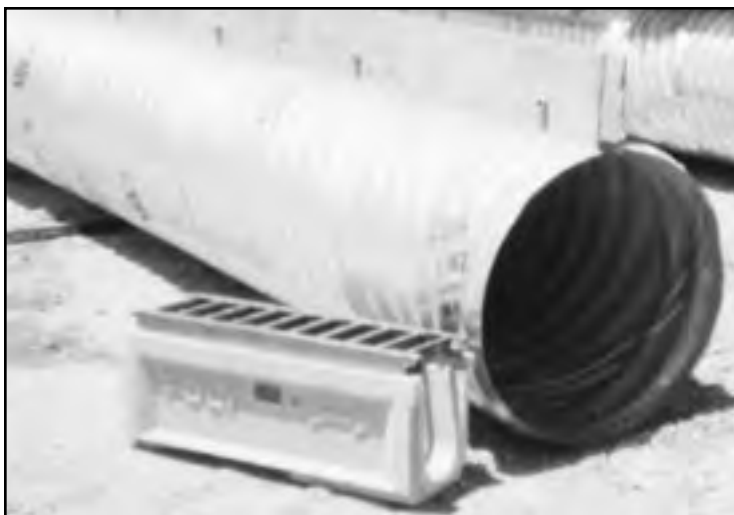

Inherent Benefits of the Interceptor System over Slotted Pipe

- Maximum inlet capacity reduces the potential for grate clogging while maintaining bicycle safety standards
- Removable grates for easier maintenance
- Built-in 0.6% channel slope eliminates need for setting grade of trench for slotted pipe
- Radius bottom and low roughness coefficient allow channels to achieve self-cleaning velocities even in flat grade situations
- Less excavation required
- Shallower flow line with Interceptor System allows greater flexibility in installations where utilities are involved

Interceptor vs. Drop Inlets

- Controls excessive spread
- Enhances existing structures
- Reduces multiple inlet requirements
- Helps control or eliminate bypass
- Stays out of traffic line in curb and gutter



Interceptor vs. Area Drains

- Simpler grading — no compound slopes
- Allows for perimeter drain design in parking areas
- Less excavation
- More economical per square inch of open area

General

The work specified in this section consists of furnishing precast polymer concrete line drains conforming to these specifications and as shown on the contract plans. The work shall include the installation of the precast drains and associated items as indicated in the contract plan.

Materials

Precast Line Drain - The precast line drain shall be manufactured using polyester polymer concrete, 155 mm (6.1 in) wide, 100 mm (4.0 in) inside width with radius bottom, 10 mm (0.394 in) minimum wall thickness, consisting of both non-sloped channels and pre-sloped channels with a minimum invert slope of 0.6%. Maximum channel depths shall be determined by hydraulics as shown in the contract plans. Channels shall have tongue and groove joints. Sidewall extensions shall be of similar material and thickness. The polymer concrete shall have a minimum compressive strength of 80 Mpa (12,000 psi).

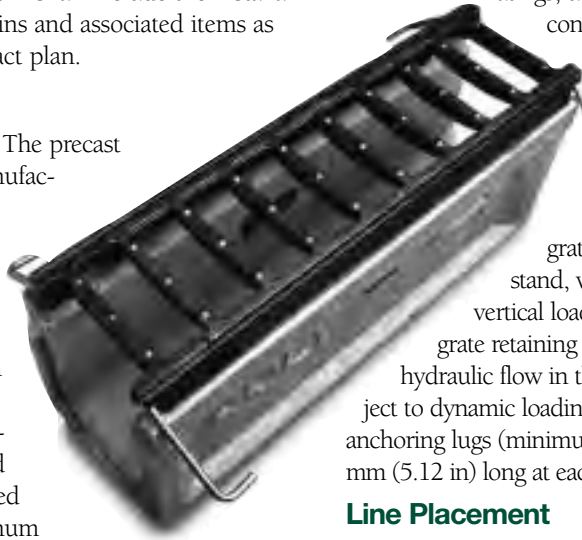

Grating and Frames

The grating and frames shall be cast ductile iron (ASTM A536-84 grade 65-45-12) or cast grey iron (ASTM A48 class 35B) and meet all AASHTO load ratings, unless otherwise noted in the contract plans. Grate inflow area shall meet or exceed hydraulic requirements.

Removable grating shall be held in place by devices resistant to tampering and snow plow forces. The grate retaining devices shall withstand, without maintenance, cyclic vertical loads of 2.2 kN (500 lbs). The grate retaining devices shall not obstruct hydraulic flow in the channels. Line drains subject to dynamic loading shall in addition have anchoring lugs (minimum 6.35 mm (0.25 in) x 130 mm (5.12 in) long at each corner of the frame.

Line Placement

The precast units shall be placed tongue and groove to specified alignment and grade per contract plan. The concrete encasement adjacent and beneath the channel shall be of equal or greater thickness (100 mm (4.0 in) minimum), be of the same compressive strength, and receive the same reinforcement as surrounding concrete; or as specified in the contract plans.

DISCLAIMER

The customer and the customer's architects, engineers, consultants and other professionals are completely responsible for the selection, installation, and maintenance of any product purchased from ABT, and EXCEPT AS EXPRESSLY PROVIDED IN ABT'S STANDARD WARRANTIES, ABT MAKES NO WARRANTY, EXPRESS OR IMPLIED, AS TO THE SUITABILITY, DESIGN, MERCHANTABILITY, OR FITNESS OF THE PRODUCT FOR CUSTOMER'S APPLICATION. Copies of ABT's standard warranties are available upon request.

PolyDrain®, PolyDyn®, PolyChampion®, GreenDot®, RedDot®, and Trench Former® are registered trademarks of ABT, Inc.®

ABT, INC.

PO Box 837 ■ 259 Murdock Road

Troutman, NC 28166

TEL 704-528-9806

FAX 704-528-5478

Toll Free 800-438-6057

Email:sales@abtdrains.com

www.abtdrains.com ©ABT, Inc. Printed in the U.S.A. 6/00



Other quality drainage products by ABT, Inc.

JEN-HILL
CONSTRUCTION MATERIALS

Ph 800-452-4435

Fax 615-822-9460

info@jenhill.com

www.jenhill.com